



A COST-EFFECTIVE RELIABLE LOAD TRANSFER SWITCH

Raritan's hybrid rack transfer switches use electromechanical relays and silicon-controlled rectifiers (SCRs) to transfer a load between two sources. The result is performance and reliability that exceeds that of standard automatic transfer switches (ATS) and at a lower cost than static transfer switches (STS).

MOST RELIABLE POWER FOR SINGLE-CORDED DEVICES

- Patented Anti-Arcing Relay technology engineered to prevent relay-welding and ensures transfer
- Blazing-fast load transfers between 4 to 8 millisecond, tested to never drop a power load in real world conditions
- Out-of-phase transfer eliminates stress about planning phases in the cabinet
- Oversized relays (Rated 70A) to handle larger loads with higher reliability
- Protect the switch with field replaceable fast-blow fuses when the device power supply shorts
- Prevents transfers of output short circuits, leading to cascading failure of second power feed
- Redundant power supply and intelligent controller architecture powered by Xerus™ Firmware
- Granular alerting and control at the outlet level uncovers risky conditions to prevent outages

EMBEDDED WITH XERUS TECHNOLOGY PLATFORM, FOR CONFIGURABLE MONITORING, CONTROL, AND ALERTING

- Xerus Firmware with Scripting, Modbus, and SNMP
- User configurable thresholds for power quality
- Alarm and status updates via GSM text, email and syslog
- Web-based configurable interface
- Hardened network security and encryption protocols: AES128, SSH, SNMPv3, Smart TLS, FIPS 140-2

PERFORMANCE FEATURES

- Hybrid Technology (relay plus SCR-design) for better power efficiency and less heat (Fan-less architecture)
- Only rack transfer switch on the market featuring Raritan patented, billing-grade (+/-1%) power metering accuracy
- World's first and only rack transfer switch with outlet-level metering and switching (on 5000 series models)
- Only rack transfer switch with power metering, energy quality monitoring, and support for optional environmental sensors
- Local display showing transfer switch status and failover conditions at-glance
- Certified to run in up to 60° C (UL), 50° C (CE) environment at 85% RH
- SecureLock™ compatible to prevent accidental disconnects

MOST TRANSFER SWITCHES ON THE MARKET FALL SHORT OF EXPECTATIONS

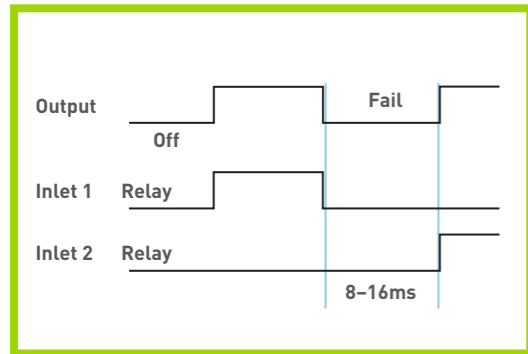

ATS (relay-based) Transfer Time

ELECTROMECHANICAL RELAY SWITCHES (ATS)

- Vendors' load transfer times vary from 8 to 16ms.
- The contacts often weld together due to electrical arcing; one of the leading causes of electromechanical relay transfer switch failure.
- Relay-only solutions do not indicate when the relay has welded and therefore no longer able to switch power feeds. Thus data center operators only know their transfer switch has failed when it's too late, i.e. there is a power failure and no switchover occurs.

SILICON-CONTROLLED RECTIFIER SWITCHES (STS)

- Offer very fast transfer times (normally 4 to 6ms), but are over five and a half times more expensive than electromechanical switches.
- Draw significantly more energy than electromechanical relays and produce more heat thereby consuming cooling resources.
- Are less energy efficient requiring forced cooling and lower maximum operating temperatures.
- Reduce the energy efficiency of the rack.

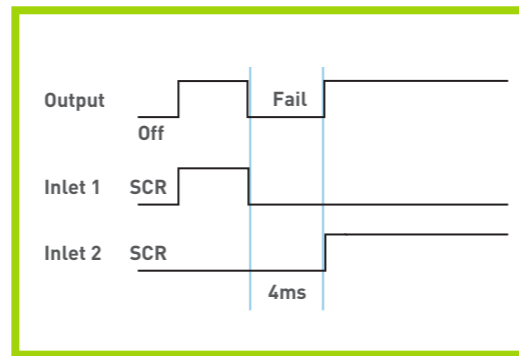

STS (SCR-based) Transfer Time

HERE'S HOW RARITAN'S IS DIFFERENT

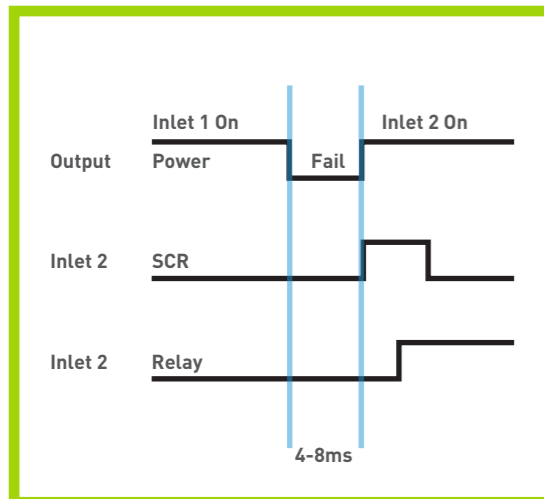

Raritan Hybrid (relay+SCR-based) Transfer Time

RARITAN'S PATENT-PENDING HYBRID DESIGN

- Solid state components provide speedy transfers.
- Patent-pending circuitry reduces wear on electro-mechanical components.
- Eliminates electrical arcing that leads to transfer relay failure.
- Identifies output short circuits and sends an alarm so the short circuit may be corrected before the power transfer is made manually.
- The PX3TS-5000 series provides outlet-level switching and metering as well as reliable power to single corded devices.
- Speed of an STS at a lower cost.
- Fan-free design for increased reliability.

RARITAN'S TRANSFER SWITCH IS FASTER, MORE INTELLIGENT, MORE RELIABLE, AND EASIER TO USE

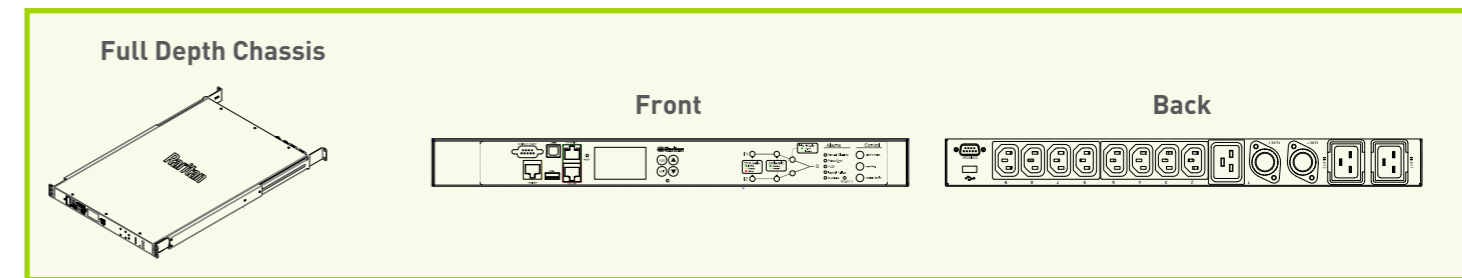
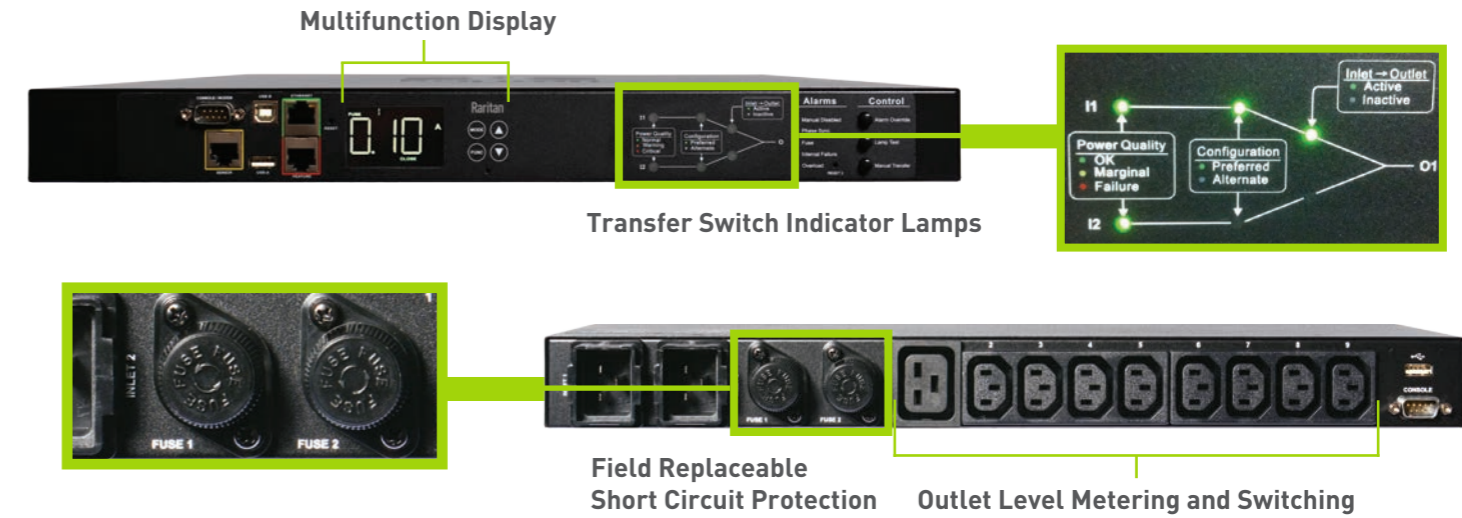

Full depth chassis allows a faster and easier access to the outlets, allowing operations teams to gain time, as devices are often stacked between 1U servers.

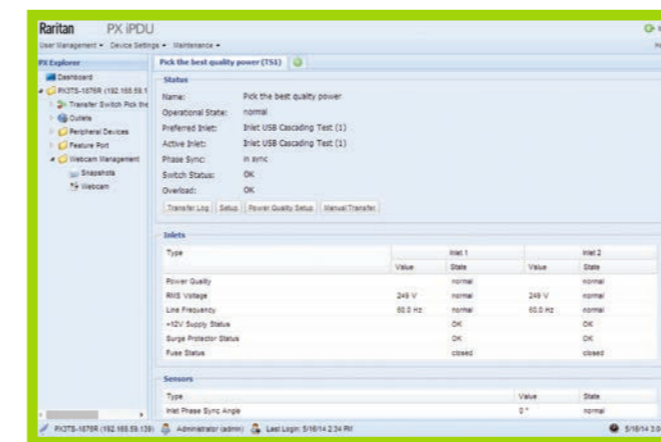

PX Intelligent Rack Transfer Switch Dashboard

SMART CONTROLLER ENABLES REMOTE MONITORING AND MANAGEMENT

- Intuitive GUI, SNMP, Modbus, TCP/IP, JSON-RPC for scripting, IPv4 / IPv6.
- Front and rear tablet access and control via USB ports.
- Threshold alerting and status updates via GSM text, email and syslog.
- Logs transfer times for reporting.
- Support for plug-and-play environment sensors.
- USB ports support Wi-Fi, camera, tablet, and cascading.



PDVIEW — INTEGRATED TABLET DISPLAY VIA USB PORT

Turns your tablet or phone into a remote display that provides at-the-rack display of all critical data. Simply plug your mobile device in the front or rear USB port to access. Available for iOS and Android devices.

WEB-BASED REMOTE POWER MONITORING

Real-time remote power quality monitoring with user definable thresholds and alerts for voltage and frequency. Includes AC waveform of last transfer and metering of power loads.

AC Waveform for Last Transfer



Model	Chassis	Input Voltage	Plug Type	Output Voltage	Outlet Type (QTY)	Current	Circuit Breaker (QTY)	10/100 Ethernet
PX3TS-5184CR	1U	200-240	(2) IEC C-20 (UL)	200-240	7 x C13; 1 x C19	16	0	Yes
PX3TS-5191CR	1U	200-240	(2) IEC C-20 (CE)	200-240	7 x C13; 1 x C19	16	0	Yes
PX3TS-1876CR	1U	200-240	(2) IEC C-20 (UL)	200-240	8 x C13; 1 x C19	16	0	Yes
PX3TS-1876R	1U	200-240	(2) NEMA L6-20P	200-240	8 x C13; 1 x C19	16	0	Yes
PX3TS-1875CR	1U	200-240	(2) IEC C-20 (CE)	200-240	C	16	0	Yes
PX3TS-1875R	1U	200-240	(2) IEC 60309 16A	200-240	8 x C13; 1 x C19	16	0	Yes
PX3TS-1875A1R	1U	240	(2) Clipsal 56P320	240	8 x C13; 1 x C19	20	0	Yes
PX3TS-1875A2R	1U	240	(2) Clipsal 56PA320	240	8 x C13; 1 x C19	20	0	Yes
PX3TS-1147R	1U	120	(2) NEMA L5-20P	120	8 x NEMA 5-20R	16	0	Yes
PX3TS-1464R	2U	200-240	(2) NEMA L6-30P	200-240	16 x C13; 4 x C19	24	2 x 20A 2-pole	Yes
PX3TS-1469R	2U	200-240	(2) IEC 60309 32A	200-240	16 x C13; 4 x C19	32	2 x 16A 1-pole	Yes
PX3TS-1469A1R	2U	240	(2) Clipsal 56P332	240	16 x C13; 4 x C19	32	2 x 16A 1-pole	Yes
PX3TS-1469A2R	2U	240	(2) Clipsal 56PA332	240	16 x C13; 4 x C19	32	2 x 16A 1-pole	Yes



ENDORSER OF THE EU CODE OF CONDUCT ON DATA CENTRE ENERGY EFFICIENCY

Formulated by the EU's Joint Research Centre, the Code is a measured response to the energy challenges the EU faces. It's aim is to encourage companies with data centers to reduce energy consumption while ensuring business objectives continue to be met.

As an endorser, Raritan have pledged to implement the Code's ethos through devising products and services that help organizations to bring their data centers into line with its best practice recommendations.

Visit www.raritan.eu or call +31 (0)10 284 4040 to learn more about the transfer switch.

